



Meggitt Fuelling Products

Avery-Hardoll
Whittaker Controls

2.5 inch self-sealing industrial couplings

with

cam operated hose units CMY6253 series
and tank units CCMY6250, CCMY6251 series

Maintenance manual with spare parts list

Publication ref TP0043

Issue 2 July 2004

Avery-Hardoll
Holland Way
Blandford Forum
Dorset DT11 7BJ
UK

Tel: +44 (0) 1258 486600
Fax: +44 (0) 1258 486601

www.meggittfuelling.com

Whittaker Controls
12838 Saticoy St
North Hollywood
California 91605-3505
USA

Tel: +1 818 765 8160
Fax: +1 818 759 2194

www.wkr.com
www.meggitt.com

The information contained herein is the property of Avery Hardoll a division of Meggitt (UK) Ltd. No part may be reproduced or used except as authorised by contract or other written permission. The Company reserves the right to alter without notice the specification, design or conditions of supply of any product or service.

MEGGITT
smart engineering for
extreme environments

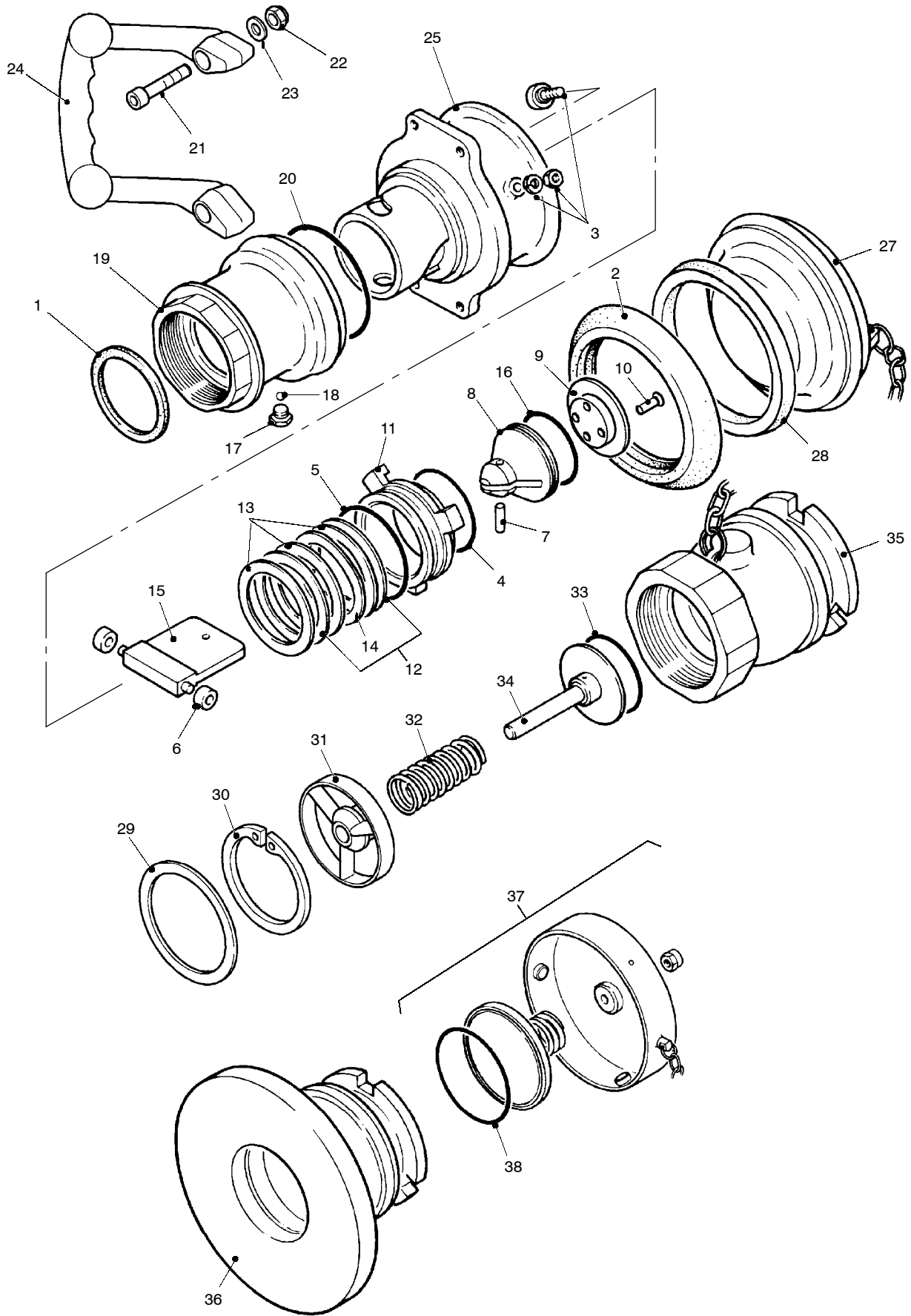

Figure 1 2 1/2 in. couplings with standard blanking caps

Spare parts identification and ordering

- The letters in the following 'Use on' column are the part number suffix letters of the coupling to which the part should be fitted. Always quote the coupling part number in full, as well as the item part number when ordering spares.

<u>Item</u>	<u>Part Number</u>	<u>Description</u>	<u>Use on</u>	<u>Qty</u>
-	-	Hose unit		Ref
1*	FCRZ430-1	. Seal, connector 2 ¹ / ₂ in. - Viton (Fluorocarbon)	V	1
	FCRZ430	. Seal, connector 2 ¹ / ₂ in. - Nitrile	N	1
2*	CCRZ13	. Ring, buffer		1
3	CCMS6288	. Bayonet roller assy		3
4*	Z032E229139A	. Seal, O-ring - Viton (Fluorocarbon)	V	1
	Z022E229139A	. Seal, O-ring - Nitrile	N	1
5*	Z032E231139A	. Seal, O-ring - Viton (Fluorocarbon)	V	1
	Z022E231139A	. Seal, O-ring - Nitrile	N	1
6	CCCZ6291	. Roller, cam		2
7	ZT4011M0824A	. Pin		1
8	NOT SPARED	. Valve		Ref
9	NOT SPARED	. Valve Cap		Ref
10	ZS3223M04020A	. Screw, countersunk, M4 x 20 lg		4
11	NOT SPARED	. Spanner ring		Ref
12	CCPZ1371	. Washer, wave spring (PTFE)		2
13	CCSZ1370	. Washer, wave spring (Stainless steel)		3
14	CCSZ1280	. Spring, wave		1
15	NOT SPARED	. Rod, connecting		Ref
16*	CCRZ1291-3	. Seal, O-ring - Viton (Fluorocarbon)	V	1
	CCRZ1291	. Seal, O-ring - Nitrile	N	1
17	CCSZ8294	. Plug		1
18	ZACZ0068-7	. Ball, ⁹ / ₃₂ in. dia		39
19	NOT SPARED	. Connector, hose - 2 ¹ / ₂ in. BSP		1
20*	Z032E236139A	. Seal, O-ring - Viton (Fluorocarbon)	V	1
	Z022E236139A	. Seal, O-ring - Nitrile	N	1
21	ZS4025M08045A	. Screw, skt cap hd, M8 x 45 lg		4
22	ZMSZ0284-3	. Stiff nut		4
23	ZW4001M08A	. Washer, plain, 8 mm		4
24	CCAS6284	. Handle		2
25	NOT SPARED	. Cam		Ref
26+	CCSZ8297	. Pin, selective (Selective builds only)		6
27	CCMY6	Hose unit dust cap - Nitrile	N	1
	CCMY6VN	Hose unit dust cap - Viton (Fluorocarbon)	V	1
28*	ZARZ0097-1	. Seal - Nitrile	N	1
	ZARZ0097-2	. Seal - Viton (Fluorocarbon)	V	1
-	-	Tank unit		Ref
29	FCRZ430-1	. Seal - Viton (Fluorocarbon) (BSP unit only)	V	1
	FCRZ430	. Seal - Nitrile (BSP unit only)	N	1
30	ZASZ0058-37	. Circlip		1
31	CCPZ6273	. Valve guide		1
32	CCSZ180	. Spring		1
33*	Z032E227139A	. Seal, O-ring - Viton (Fluorocarbon)	V	1
	Z022E227139A	. Seal, O-ring - Nitrile	N	1
34	NOT SPARED	. Valve assy		Ref
35	NOT SPARED	. Body, screwed		Ref
36	NOT SPARED	. Body, flanged		Ref
37	CCMY5	Tank unit blanking cap assy - Nitrile	N	1
	CCMY5VN	Tank unit blanking cap assy - Viton (Fluorocarbon)	V	1
38*	ZARZ0041-9	. Seal, O-ring - Nitrile	N	1
	ZARZ0041-10	. Seal, O-ring - Viton (Fluorocarbon)	V	1
39+	CCMY1400	Tank unit locking cap assy - Nitrile	N	1
	CCMY1400VN	Tank unit locking cap assy - Viton (Fluorocarbon)	V	1

* = Suggested spare part

Ref = Reference only

+ = Item not illustrated

General

- The 2¹/₂ inch couplings are supplied with a choice of seal materials and with optional selectivity to suit a particular application or customer requirement. The coupling build standard is indicated by the part number suffix letters:

1st suffix; V or N = seal material

2nd suffix; SA to SW (excepting SI and SO) = selectivity (optional)

Data:

Working pressure (max) 12 bar (175 psi)

Coupling pressure (max, no-flow conditions) 4 bar (60 psi)

Static test pressure 18 bar (265 psi)

Operating temperature range:

Fluorocarbon (Viton) seals (Part No. suffix V) -20 to +120 deg C (-4 to +248 deg F)

Nitrile (Part No. suffix N) -30 to +120 deg C (-22 to +248 deg F)

WARNING: DO NOT HANDLE O-RING SEALS IF THEIR MATERIAL APPEARS CHARRED, GUMMY OR STICKY. USE TWEEZERS AND WEAR NEOPRENE OR PVC GLOVES. DO NOT TOUCH ADJACENT PARTS WITH UNPROTECTED HANDS. NEUTRALIZE ADJACENT PARTS WITH A SOLUTION OF CALCIUM HYDROXIDE. IF THE DEGRADED MATERIAL OR ADJACENT PARTS TOUCH THE SKIN, DO NOT WASH OFF WITH WATER, SEEK IMMEDIATE MEDICAL AID FOR POSSIBLE CONTAMINATION WITH HYDROFLUORIC ACID. HYDROFLUORIC ACID IN CONTACT WITH SKIN HAS DELAYED SYMPTOMS OF CONTAMINATION. IT IS EXTREMELY TOXIC.

User Instructions

- Cleanliness is essential for trouble-free operation of the couplings. Always ensure that blanking caps are installed when units are disconnected.
- Periodically examine couplings for contamination, evidence of leakage and damage. Clean couplings, as necessary, with lint-free cloth or a soft bristle brush moistened with a suitable cleaning agent; pay particular attention to hose unit and tank unit seal recesses.

Repair

- Repair of couplings is by replacement of faulty seals and worn or damaged components. Repair procedures are straightforward and no special tools are required. Refer to exploded views and the following outline procedures for guidance.

Dismantling notes

- *Hose units:* Separate hose connector (17) from cam (23) by removing plug (15) and rotating hose connector to release bearings (16); collect cam rollers (6). Remove cap nuts and spring washers and the three bayonet rollers (3) from the cam. Remove spanner ring (9) and valve components from the cam. Remove pin (7) to separate valve (8) from connecting rod (13).
- *Tank units:* The valve in the tank unit is spring loaded and care must be taken to avoid injury when removing the valve guide. Hold the valve guide (29) in place and carefully remove the circlip (28). Allow the spring to expand slowly, and remove the valve guide, spring (30) and valve assembly (32).

Cleaning and Inspection

- Clean all metal components using lint-free cloth moistened with a suitable non-toxic cleaning fluid. Ensure that residues of seal material are removed from O-ring seal grooves and from all sealing faces; use fine grade wire wool, if necessary.
- Examine all parts for damage, evidence of wear and condition of surface protection (Fluoron coated components). Discard unserviceable components together with all used seals and pins; refer to spares list for replacement parts.

Assembling

- Assemble units in the reverse order of dismantling and note the following:
- Exercise care when installing O-ring seals in 'dovetail' grooves; use a suitable lubricant if necessary, and wipe off any excess after assembly.
- When installing the spanner ring in the hose unit, ensure that the stops are positioned under the bayonet roller locations.
- Ensure that the handles are correctly orientated on the hose unit.
- The Nyloc nut securing the seal support plate in the tank unit blanking cap must be slackened approximately one turn to allow the seal plate to rotate in the cap.

Testing

- Couple the repair unit to a serviceable hose or tank unit as appropriate and check for correct operation of valve actuating and bayonet locking mechanism. Couple and uncouple unit(s) several times.