

Meggitt Fuelling Products
Avery-Hardoll
Whittaker Controls

Illustrated Parts List

4-Inch Valve Body and Piston Assembly

[M300]

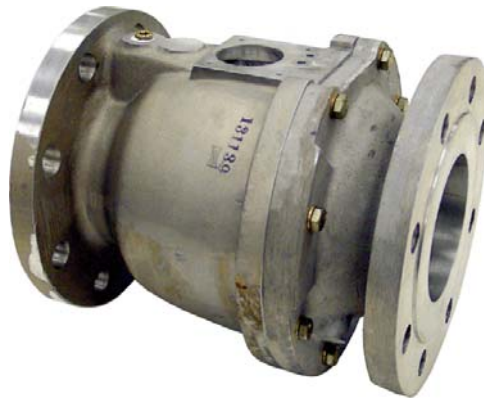

Whittaker Controls

12838 Saticoy Street
North Hollywood
CA 91605-3505
USA

Tel: +1 818 765 8160
Fax: +1 818 759 2194

www.wkr.com
www.meggitt.com

Avery-Hardoll

Holland Way
Blandford Forum
Dorset DT11 7BJ
UK

Tel: +44 (0) 1258 486600
Fax: +44 (0) 1258 486601

www.meggittfuelling.com
www.meggitt.com

MEGGITT

NOTICE: Proprietary information of Meggitt Fuelling Products. The information contained in this document is disclosed in confidence. It is the property of Meggitt Fuelling Products, and shall not be used, disclosed to others, or reproduced in whole or in part without the express written consent of Meggitt Fuelling Products. If consent is given this notice shall appear in any such reproduction. These commodities, technology or software were exported from the United States in accordance with the export administration regulations. Diversion contrary to U.S. law is prohibited.

Revision 1.1 – 02/01/2006

Meggitt Fuelling Products
Illustrated Parts List
4-Inch Valve Body and Piston Assembly

LIST OF EFFECTIVE PAGES

On a revised page, the portion of text or illustrations affected by the change is indicated by a vertical line in the outer margin of the page. When a revision is issued, the entire document is reissued with the current revision number and date shown on all pages. For major revisions, the basic number is incremented. For minor revisions, the number following the decimal is incremented. Dates of issue for original and subsequent revisions are as follows:

Original 1.0 05/15/2002
Revision 1.1 02/01/2006

The total number of pages in this technical document is 11 consisting of the following:

Title, 2 – 11

TABLE OF CONTENTS

SUBJECT	PAGE
Introduction	3
4-Inch In-Line Valve Body and Piston Assembly	4
4-Inch by 2½-Inch Hydrant Valve Body and Piston Assembly	7
4-Inch by 4-Inch Hydrant Valve Body and Piston and Body Assembly	9

Meggitt Fuelling Products
Illustrated Parts List
4-Inch Valve Body and Piston Assembly

INTRODUCTION

1. General

This illustrated parts list lists, describes, and illustrates all detail parts required for maintenance support of the 4-Inch Valve Body and Piston Assembly.

2. Scope of Information

A. The parts list is arranged in the general order of disassembly. The listing is indented to show the relationship between each part and its next higher assembly. Item numbers used in the parts list are keyed to the corresponding numbers of the accompanying illustration.

B. MODIFICATION CODE

The modification code indicates the parts usage with respect to the end item. When the MODIFICATION CODE column is blank, the part usage is applicable to all versions unless otherwise specified in the DESCRIPTION column.

C. How to Identify a Part

1) **When the part number is known:** Refer to the parts list for the item number, description, modification codes, and quantity. Refer to the illustration to verify the physical appearance and location of the part.

2) **When the part number is not known:** Review the illustrations to identify the part by physical appearance and location. Refer to the accompanying parts list to obtain the part number, description, modification codes, and quantity.

D. Abbreviations

ASSY	Assembly.
FIG.	Figure.
IPL	Illustrated Parts List.
MOD	Modification.

Meggitt Fuelling Products
Illustrated Parts List
4-Inch Valve Body and Piston Assembly

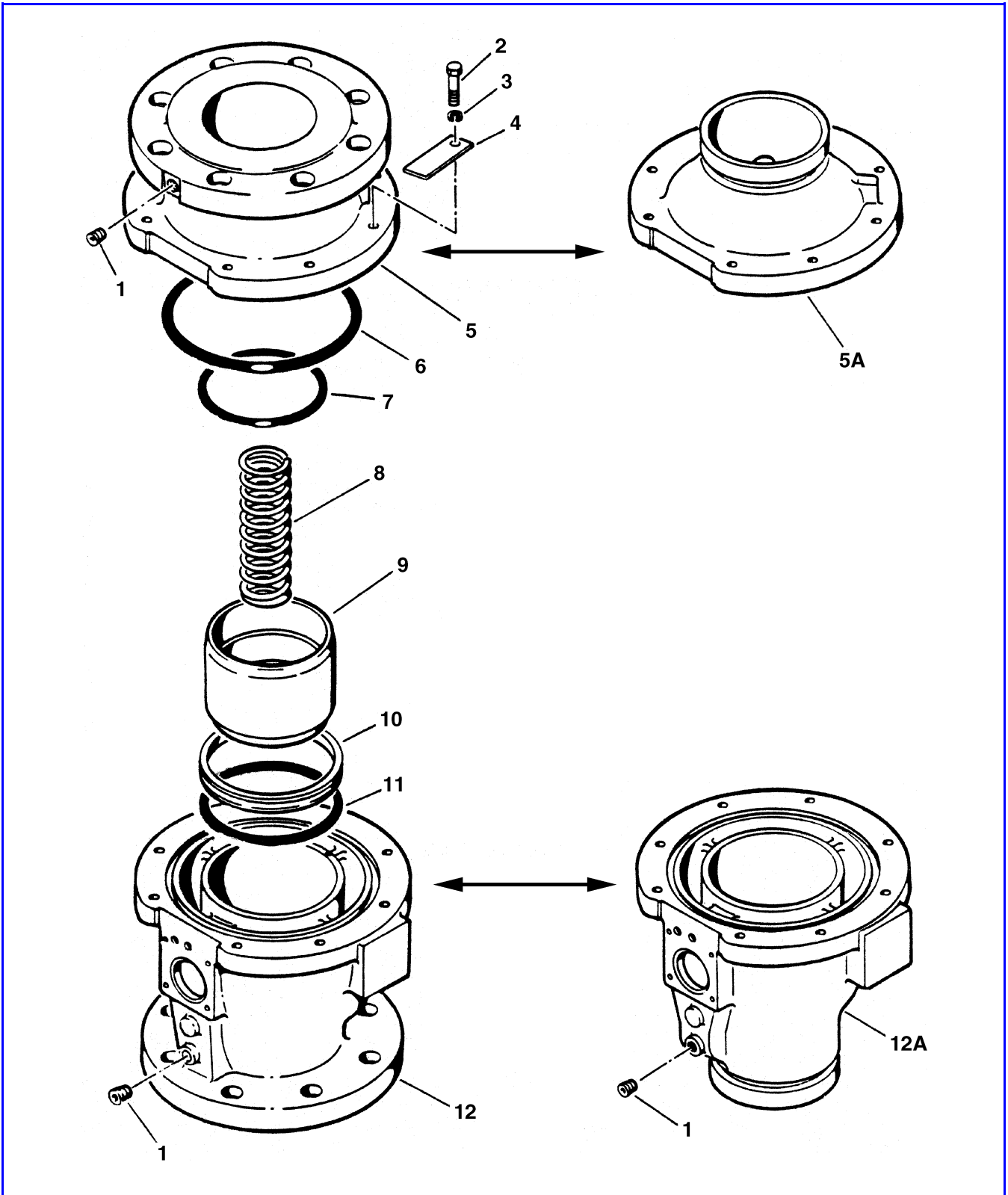

IPL Figure 1. 4-Inch In-Line Control Valve Body and Piston Assembly

Meggitt Fuelling Products
Illustrated Parts List
4-Inch Valve Body and Piston Assembly

FIG. ITEM	PART NUMBER	DESCRIPTION							MOD CODES	UNITS PER ASSY
		1	2	3	4	5	6	7		
1	(Basic)	VALVE BODY AND PISTON ASSEMBLY, In-Line Control, 4-inch								REF
1	CAN932-3	• PLUG								2
2	3/8-24X1-1/2	• BOLT, MACHINE								8
3	CAN960-616	• WASHER, FLAT								8
4	2691179-1	• PLATE, IDENTIFICATION								1
5	2672306-1	• FITTING, OUTLET (Flanged) (Aluminum alloy)								1
	2672306-2	• FITTING, OUTLET (Flanged) (Ductliron)							B	1
5A	2672163-1	• FITTING, OUTLET (Victallic) (Aluminum alloy)							D	1
	2672163-2	• FITTING, OUTLET (Victallic) (Ductliron)							BD	1
6	CMS29513-263	• PACKING, PREFORMED								1
7	CMS29513-245	• PACKING, PREFORMED								1
8	2672165	• SPRING, COMPRESSION								1
9	2632643-2	• PISTON, VALVE								1
10	4631062-247	• SEAL								1
11	2661058BD248	• PACKING, PREFORMED								1
12	2672169-1	• BODY, VALVE (Flanged inlet) (Aluminum alloy)								1
	2672169-2	• BODY, VALVE (Flanged inlet) (Ductliron)							B	1
12A	2672161-1	• BODY, VALVE (Victaulic inlet) (Aluminum alloy)							C	1
	2672161-2	• BODY, VALVE (Victaulic inlet) (Ductliron)							BC	1

4-INCH IN-LINE CONTROL VALVE BODY AND PISTON ASSEMBLY VARIATIONS	
MOD LETTER	DESCRIPTION
B	Changes material to Ductliron.
C	Changes body to body with Victaulic inlet.
D	Adds Victaulic outlet fitting.

Meggitt Fuelling Products
Illustrated Parts List
4-Inch Valve Body and Piston Assembly

4-INCH IN-LINE CONTROL VALVE BODY AND PISTON ASSEMBLY MAINTENANCE NOTES	
--	--

NOTE	MAINTENANCE INFORMATION
1	When the seal (12) is replaced, the new seal must be roll-formed by hand to fit over the packing (13) before it is installed.

4-INCH IN-LINE CONTROL VALVE BODY AND PISTON ASSEMBLY REPLACEMENT PARTS KITS AVAILABLE		
---	--	--

KIT PART NUMBER	DESCRIPTION	ITEMS IN KIT (IPL Figure 1)
2702278-1	Seals	6, 7, 10, 11

Meggitt Fuelling Products
 Illustrated Parts List
 4-Inch Valve Body and Piston Assembly

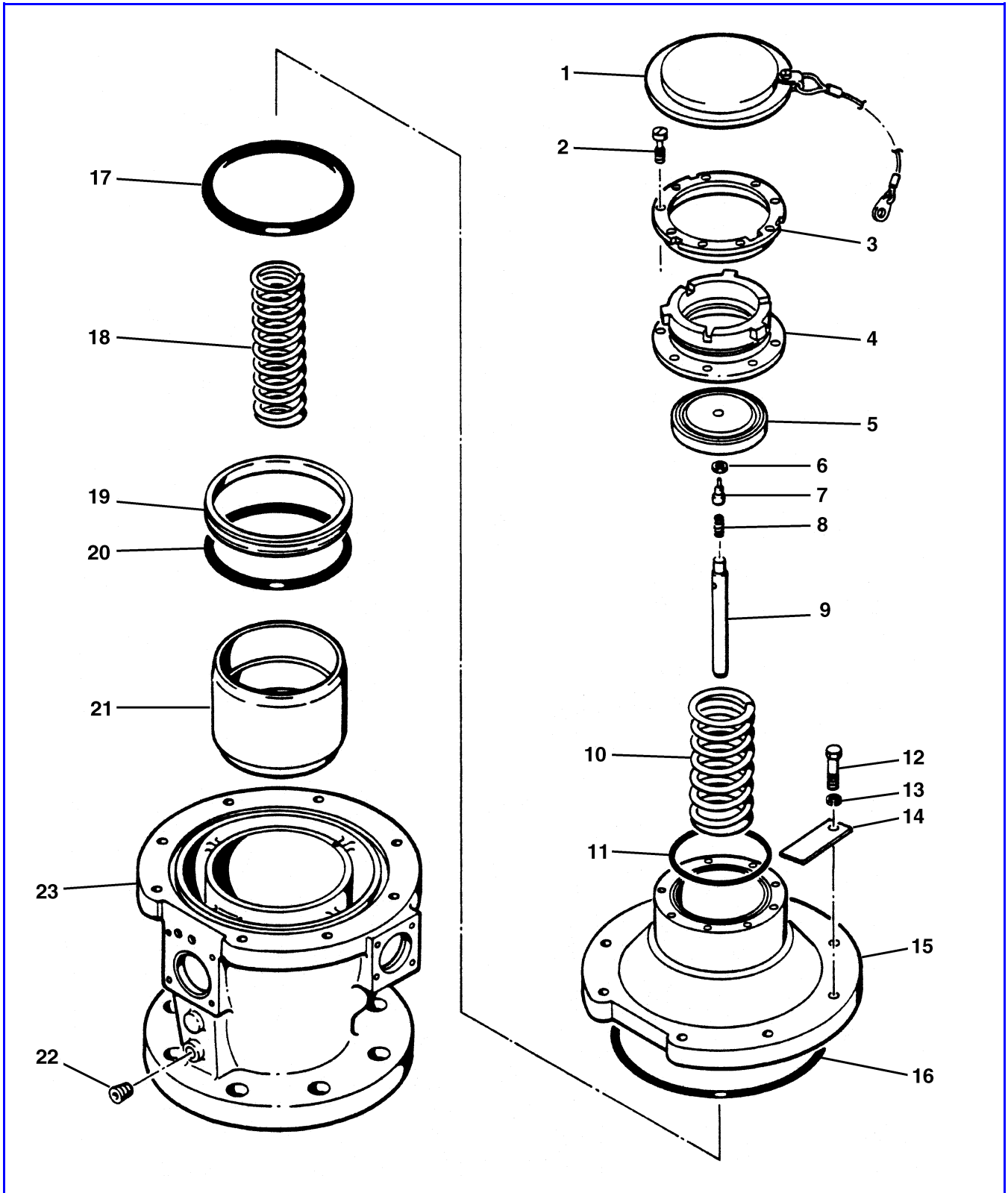

IPL Figure 2. 4-Inch by 2½-Inch Hydrant Valve Body and Piston Assembly

Meggitt Fuelling Products
Illustrated Parts List
4-Inch Valve Body and Piston Assembly

FIG. ITEM	PART NUMBER	DESCRIPTION							UNITS PER ASSY
		1	2	3	4	5	6	7	
2	(Basic)	VALVE BODY AND PISTON ASSEMBLY, Hydrant, . . . 4-inch by 2½-inch							REF
1	2682050	• COVER, PROTECTIVE							1
2	2681245	• SCREW, SELF-LOCKING							9
3	2681246-1	• RING, PRODUCT SELECTION							1
4	1427-595185-2	• FLANGE (Safety shear)							1
5	2682052-1	• POPPET							1
6	2681965	• GASKET							1
7	2681261-3	• PLUNGER							1
8	2-1349-46	• SPRING							1
9	2681260	• SHAFT							1
10	2691265	• SPRING, COMPRESSION							1
11	CMS29513-43	• PACKING, PREFORMED							1
12	MS90727-64	• BOLT, MACHINE							8
13	CAN960C616	• WASHER, FLAT							8
14	2691179-1	• PLATE, IDENTIFICATION							1
15	2681241-2	• ADAPTER							1
16	CMS29513-263	• PACKING, PREFORMED							1
17	CMS29513-245	• PACKING, PREFORMED							1
18	2661925	• SPRING, COMPRESSION							1
19	4631062-247	• SEAL							1
20	2661058BD248	• PACKING, PREFORMED							1
21	2632643-2	• PISTON, VALVE							1
22	CAN932-3S	• PLUG							1
23	2672169-3	• BODY, VALVE (Aluminum alloy)							1

4-INCH BY 2½-INCH HYDRANT VALVE BODY AND PISTON ASSEMBLY MAINTENANCE NOTES	
NOTE	MAINTENANCE INFORMATION
1	Use thread locking compound on the threads of the shaft (9).
2	When the seal (19) is replaced, the new seal must be roll-formed by hand to fit over the packing (20) before it is installed.

4-INCH BY 2½-INCH HYDRANT VALVE BODY AND PISTON ASSEMBLY REPLACEMENT PARTS KITS AVAILABLE		
KIT PART NUMBER	DESCRIPTION	ITEMS IN KIT (IPL Figure 2)
KITF372	Seals	6, 11, 16, 17, 19, 20

Meggitt Fuelling Products
 Illustrated Parts List
 4-Inch Valve Body and Piston Assembly

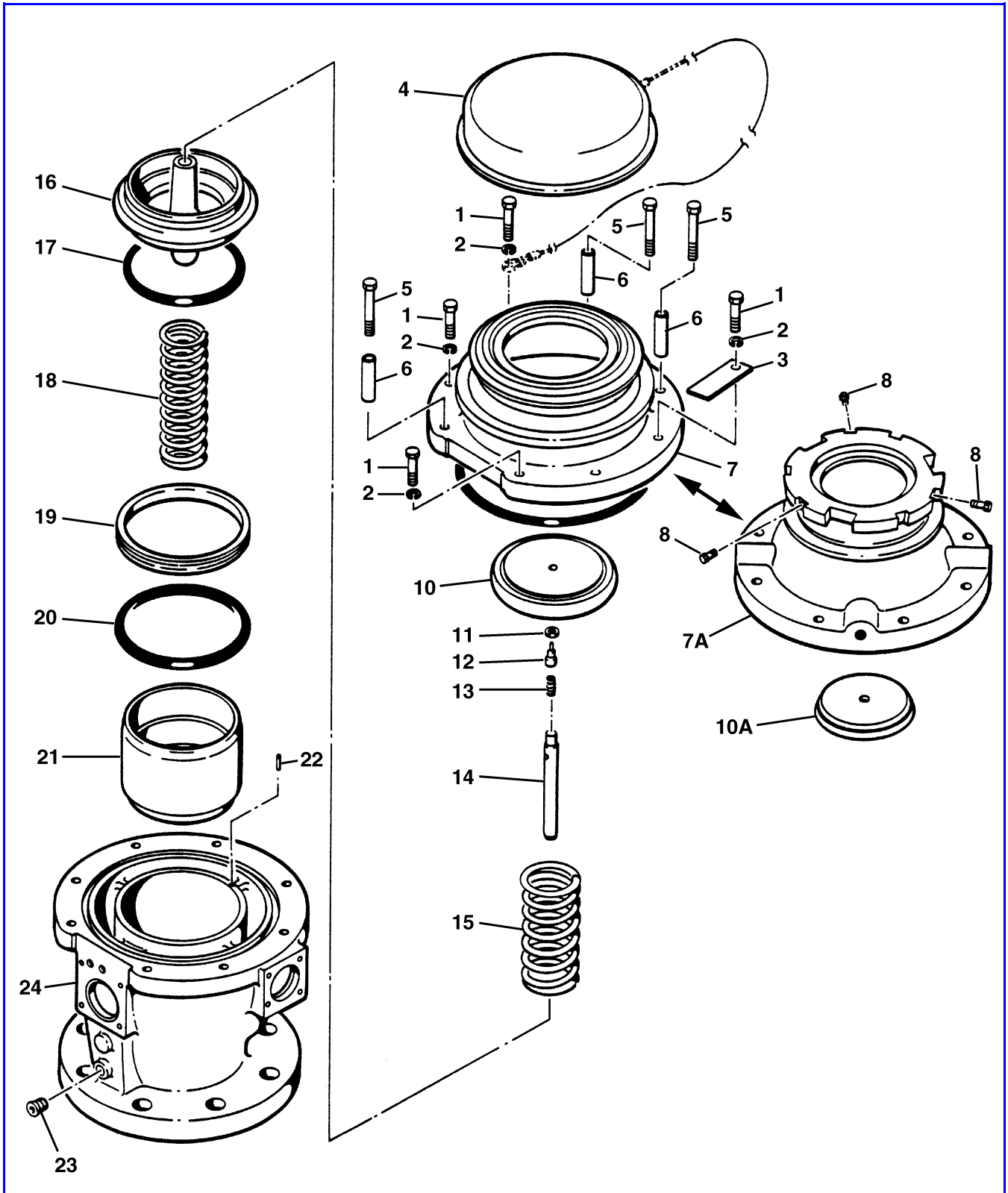

IPL Figure 3. 4-Inch by 4-Inch Hydrant Valve Body and Piston Assembly

Meggitt Fuelling Products
Illustrated Parts List
4-Inch Valve Body and Piston Assembly

FIG. ITEM	PART NUMBER	DESCRIPTION 1 2 3 4 5 6 7	USAGE CODES	UNITS PER ASSY
3	(Basic)	VALVE BODY AND PISTON ASSEMBLY, Hydrant, 4-inch by 4-inch		REF
1	MS90727-64	• BOLT, MACHINE	Not used on B,F,K	5
2	2681249-1	• SPACER		5
	2681249-1	• SPACER	B,F,K	8
3	2691179-1	• PLATE, IDENTIFICATION		1
4	2681255	• COVER, PROTECTIVE		1
5	MS90727-71	• BOLT, MACHINE		3
	MS90727-64	• BOLT, MACHINE	B,F,K	8
6	2681249-1	• SPACER	Not used on B,F,K	3
7	2681172-2	• FLANGE		1
7A	2681934-2	• FLANGE	B,F,K	1
8	LP501D416-10	• SCREW, SELF-LOCKING (Used only when more than one product selection is used)	B,F,K	6
9	CMS29513-263	• PACKING, PREFORMED		1
10	2681242-2	• POPPET		1
10A	2691221	• POPPET	B,F,K	1
11	2681965	• GASKET		1
12	2681261-1	• PLUNGER	A	1
	2681261-2	• PLUNGER	B,F,K	1
13	2-1349-46	• SPRING		1
14	2681260	• SHAFT		1
15	2681220	• SPRING, COMPRESSION		1
16	2681213-1	• GUIDE		1
17	CMS29513-245	• PACKING, PREFORMED		1
18	2661925	• SPRING, COMPRESSION		1
19	4631062-247	• SEAL		1
20	2661058BD248	• PACKING, PREFORMED		1
21	2632643-2	• PISTON, VALVE		1
22	CMS171555	• PIN		1
23	CAN932-3S	• PLUG		2
24	2672169-3	• BODY, VALVE (Aluminum alloy)		1
	2672169-3	• BODY, VALVE (Ductliron)	C,D,E, G,H,J	1

Meggitt Fuelling Products
Illustrated Parts List
4-Inch Valve Body and Piston Assembly

4-INCH BY 4-INCH HYDRANT VALVE BODY AND PISTON USAGE CODES	
CODE LETTER	DESCRIPTION
(No Code)	Item is used on all valve versions.
A	Used on F368.
B	Used on F368B.
C	Used on F368E.
D	Used on F372E.
E	Used on F373.
F	Used on F373A.
G	Used on F374.
H	Used on F380.
J	Used on F382.
K	Used on F382A.

4-INCH BY 4-INCH HYDRANT VALVE BODY AND PISTON ASSEMBLY MAINTENANCE NOTES	
NOTE	MAINTENANCE INFORMATION
1	Use thread locking compound on the threads of the shaft (14).
2	When the seal (19) is replaced, the new seal must be roll-formed by hand to fit over the packing (20) before it is installed.

4-INCH BY 4-INCH HYDRANT VALVE BODY AND PISTON ASSEMBLY REPLACEMENT PARTS KITS AVAILABLE		
KIT PART NUMBER	DESCRIPTION	ITEMS IN KIT (IPL Figure 3)
KITF368-101	Seals	9, 11, 17, 19, 20