

AIR/FUEL SENSE PLUG AND SOCKET F554 AND F571

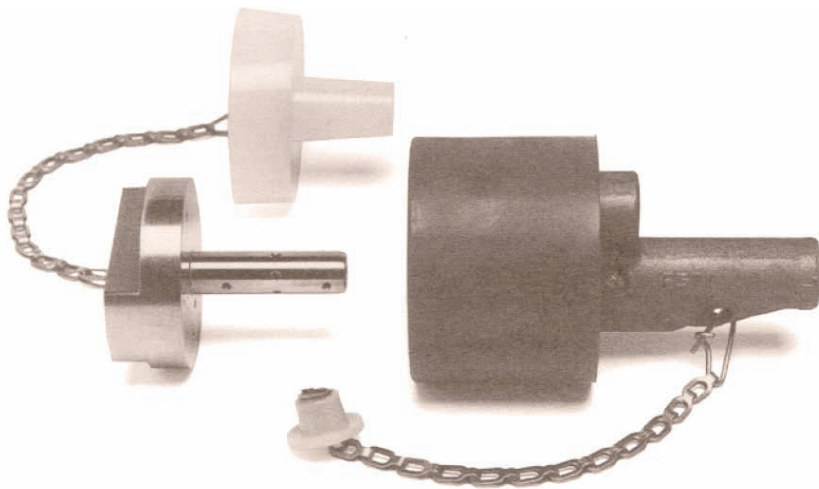

Air/fuel sense F554 plug and F571 socket

Whittaker air/fuel sense quick couplings are designed to transmit both air and fuel pressure from a hydrant servicing vehicle to a hydrant pit valve or a pressure control coupler. A simple push together and pull apart action allows easy connection. The socket provides self-sealing of the fuel line and venting of the air line to atmosphere when disconnected. Both air and fuel lines from the plug are vented during disconnection.

Envelope dimensions

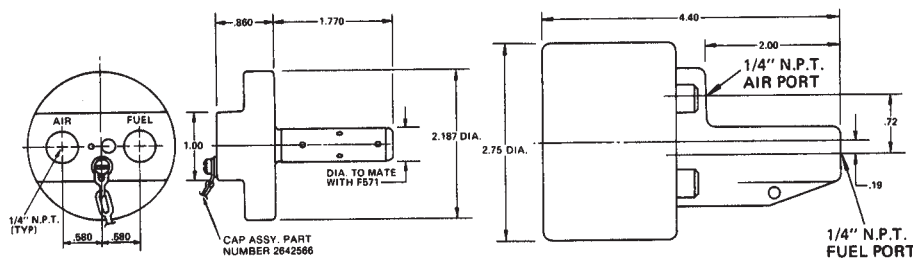

See the modification section of this catalog for various options to the part number listed above.

Contact your local Whittaker distributor or Whittaker directly for technical information beyond that listed in the technical section of this catalog.

Features

- Texin bumper on socket absorbs shock of normal handling
- Fuel valve actuator in socket is recessed to prevent inadvertent opening and damage from rough handling
- Inlet to socket is aluminum bronze and replaceable
- Abrasion resistant "O" rings provide seals between air and fuel passages
- Well-rounded holes used for passages on plug to prevent cutting of seals during connection
- Stainless steel used for plug, not soft brass
- Socket disassembles for seal, replacement
- Five position product selection available

Ordering data

Several modifications of both the F554 Plug and F571 Socket are available as noted in the table of modifications.

AIR/FUEL SENSE PLUG AND SOCKET

F554 AND F571

F571 PARTS BREAKDOWN

Sym	Part No.	Description	Req'd	Modification Used On
1	2672330-1	Socket Body	1	All
1A	2672330-2	Socket Body	1	H
2	2803200-101	Bumper	1	All
3	2672326	Pin	1	All
4	NAS561C3-12	Pin	1	All
5	2661058BD005	Packing	1	All
*6	2823009-101	Stem	1	All
7	2672397	Screw	1	All
8	2681827	Seat	1	All
9	LC-032E-10MW	Spring	1	All
10	5005-43H	Retainer	1	All
11	568-112	"Q" Ring	1	All
12	2661058K112	Packing	2	All
13	2661058K027	Packing	1	All
14	2672339-11	End	1	Basic
14A	2672339-1	End	1	A
14B	2672339-2	End	1	B
14C	2672339-3	End	1	C
14D	2672339-5	End	1	F
14E	2672339-6	End	1	G
15	2672328	Dust Plug Assy.	1	All
16	LP1351-4-20	Screw	4	Basic, A
16A	LP1351-4-16M	Screw	4	B,C,F,G
17	2713531	Retainer	1	All
18	2841003-101	Spacer	2	All
*19	5105-9H	Retainer	1	All

Notes: 1. All packings should be lubricated with petroleum jelly
 2. Set screw (7) to be set to dimension shown.
 Special tool F80-0-1304 must be used for this purpose.

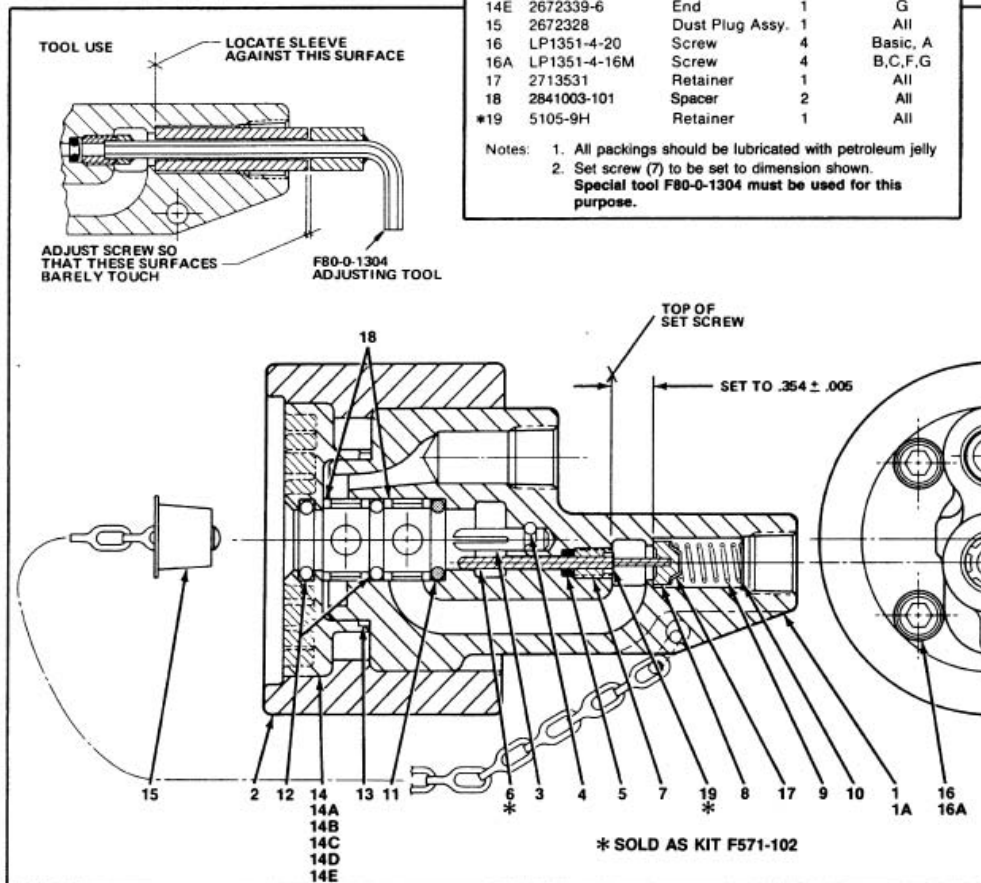

Avery-Hardoll
 Holland Way
 Blandford Forum
 Dorset DT11 7BJ
 UK

Whittaker Controls
 12838 Saticoy St
 North Hollywood
 California 91605-3505
 USA

Tel: +44 (0) 1258 486600
 Fax: +44 (0) 1258 486601

Telephone: +1 818 765 8160
 FAX: + 1818 759 2194

www.meggittfuelling.com

www.wkr.com
 www.meggitt.com

MEGGITT