

# Meggitt Fuelling Products

## Avery-Hardoll Whittaker Controls

### RATE OF FLOW LIMITER PILOT VALVE F540-1 FOR THREE-INCH AND FOUR-INCH VALVES F540-2 FOR SIX-INCH VALVES OVERWING FUELLING SPOUT F559

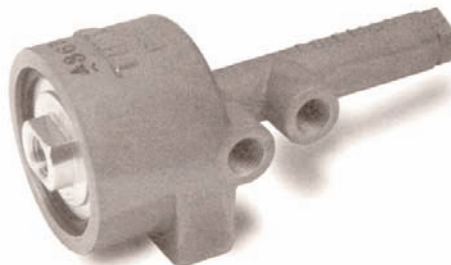

F540

#### F559 emergency overwing fuelling spout

The F559 Spout is available for use with Whittaker F100, F105, F110, F114, F115, F116 and F117 for emergency overwing airplane fueling, and for filling miscellaneous vehicles. It is available with a safety locking lug to prevent inadvertent disconnect.

#### F540 rate-of-flow pilot

The Whittaker F540 rate-of-flow pilot is designed for use in those fuelling systems requiring a "topping" rate control to override the primary pressure control. This may be desired due to flow-limitations on meters or filters. It is easily adjusted during flow conditions, and is very simple, using a polished, plated piston (no diaphragm) with a Teflon seal for low friction and long life. A typical application schematic is shown on the back page.

Note: use F540-1 with three and four-inch control valves and F540-2 with six-inch control valves.

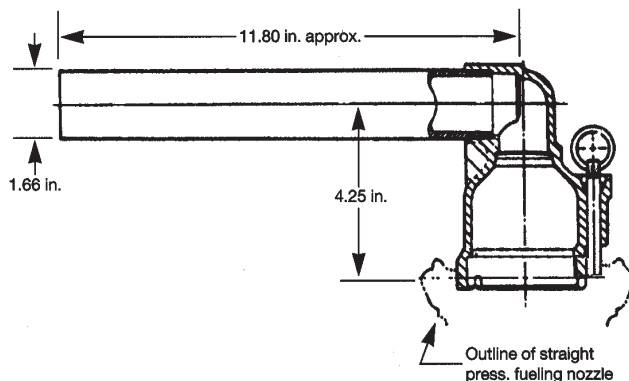

See the modification section of this catalog for various options to the part number listed above.

Contact your local Whittaker distributor or Whittaker directly for technical information beyond that listed in the technical section of this catalog.

#### Features

- Simple construction - no moving parts to wear out
  - Bayonet flange and locking lug for positive locking and sealing to nozzle
  - Lightweight, aluminum alloy construction
- Standard 559 spout:  
50 gpm flow at 50 psi nozzle inlet pressure
- Optional F559A spout:  
250 gpm flow at 50 psi nozzle inlet pressure
  - Optional F559B spout:  
50 gpm - deletes locking lug
  - Optional F559AB spout:  
250 gpm - deletes locking lug

MEGGITT

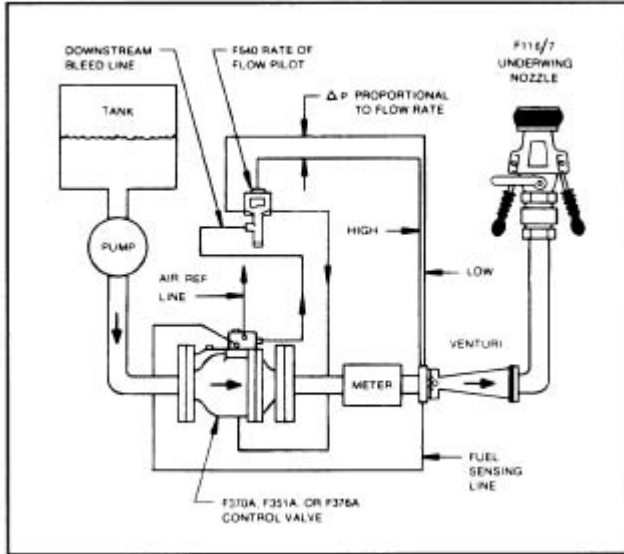

### F540 Flow control pilot (Weight 2.63 lbs)

#### Operation schematic

The F540 senses, at its HIGH and LOW ports, a pressure differential across any fixed restriction in the fueling system, (which provides a pressure differential anywhere from two to 10 psi at the flow rate to be controlled) such as an orifice plate or venturi, and thereby indirectly senses flow. The INLET and OUTLET ports are connected in series into the integral downstream bleed line of the pressure control valve. The Whittaker F540 is easily adjusted under flow conditions by introducing a flow higher than desired and then turning the adjustment screw until the flow decreases to the desired point. The F540 can be mounted at any convenient location near the control valve.

**Avery-Hardoll**  
Holland Way  
Blandford Forum  
Dorset DT11 7BJ  
UK

Tel: +44 (0) 1258 486600  
Fax: +44 (0) 1258 486601

[www.meggittfuelling.com](http://www.meggittfuelling.com)

**Whittaker Controls**  
12838 Saticoy St  
North Hollywood  
California 91605-3505  
USA

Telephone: +1 818 765 8160  
FAX: + 1818 759 2194

[www.wkr.com](http://www.wkr.com)  
[www.meggitt.com](http://www.meggitt.com)

**MEGGITT**