

Fuelling products

# JET LEVEL SENSOR OVERFILL PROTECTION F613

The Meggitt Jet Level Sensor provides high level control for bottom loading systems without the use of moving parts. There are no parts to wear out, hence it lasts indefinitely. It can be used as a two-stage control to provide extremely accurate level control. Unlike its predecessor (F608), the (F613) does not need an auxiliary pressure regulator. Proper function is possible with inlet pressures to 200 psi. The Jet Level Sensor is designed to provide a “Fail Safe” system – line breakage, etc... prevents transmission of pressure signal to main shutoff valve causing flow to stop. It can be used with several Meggitt Internal Valves or line mounted control valves to provide the system required.

## How The Jet Level Sensor Functions

The F613 is shown in schematic form in figure 1 and consists of two nozzles, one in a series with a receiving orifice (receiver). When pressure is imposed upon the nozzle, it causes a small jet stream to be transmitted to the receiver. This pressure signal is used to open a pilot valve, an integral part of a shutoff valve in the main flow line to the tank. When the level in the tank reaches the jet stream, the stream becomes submerged. The jet stream passing the secondary nozzle effects a pressure lower than the tank pressure. This aspirating effect results in a secondary jet stream being created at right angles to the main stream. The submergence of the jet stream and the intersection of the two streams reduce the pressure signal transmitted to the receiver. This causes the pilot valve to close shutting off flow through the shutoff valve.

## Features

- Can be used with pressures up to 200 psi.
- No moving parts – nothing to wear out.
- No maintenance – no spare parts have ever been sold for F613 or older F608.
- Lighter than float type pilots – weighs less than 1 pound.
- Fail Safe – line breakage or stoppage prevents transmission of pressure signal to main shutoff valve stopping flow.

The F613 Jet Level Sensor is available in several variations as noted below.

**Table 1. Modifications - Basic F613 Weighs 0.4 Lbs.**

Example: F613BEF = Two F613's on 1/2-13 UNC-2B threaded mounting stud with collector and pre-check cans.

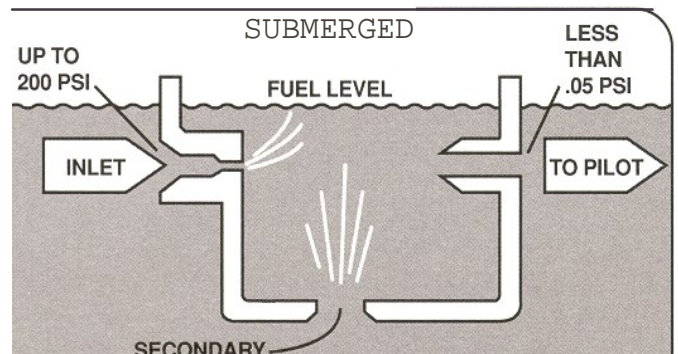
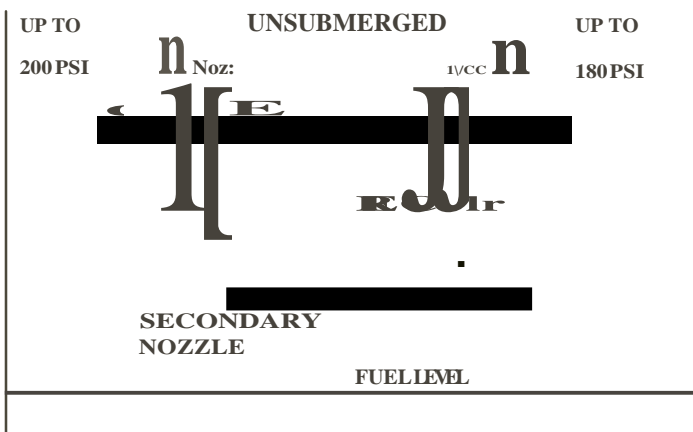

## Meggitt Control Systems

Our product competencies & services:  
Aerospace valves | Thermal management solutions | Environmental control systems | Electro-mechanical products  
Ground fuelling products | Energy products | Aftermarket services

Fuelling products

# JET LEVEL SENSOR OVERFILL PROTECTION F613

## Installation Hints:

- When using optional mounting stud use flexible tubing in sufficient length to allow vertical movement of Jet Level Sensor.
- Tubing must be 3/8" dia. minimum
- Adjustment of the F613 with optional mounting stud can be done from the top of the truck.
- Don't use threaded mounting holes when using the optional mounting stud.
- Use small plugs provided to tune precheck system to obtain desired results. Plug one hole at a time, operate precheck to determine time. If precheck doesn't function, plug another hole. At least one hole must be open.

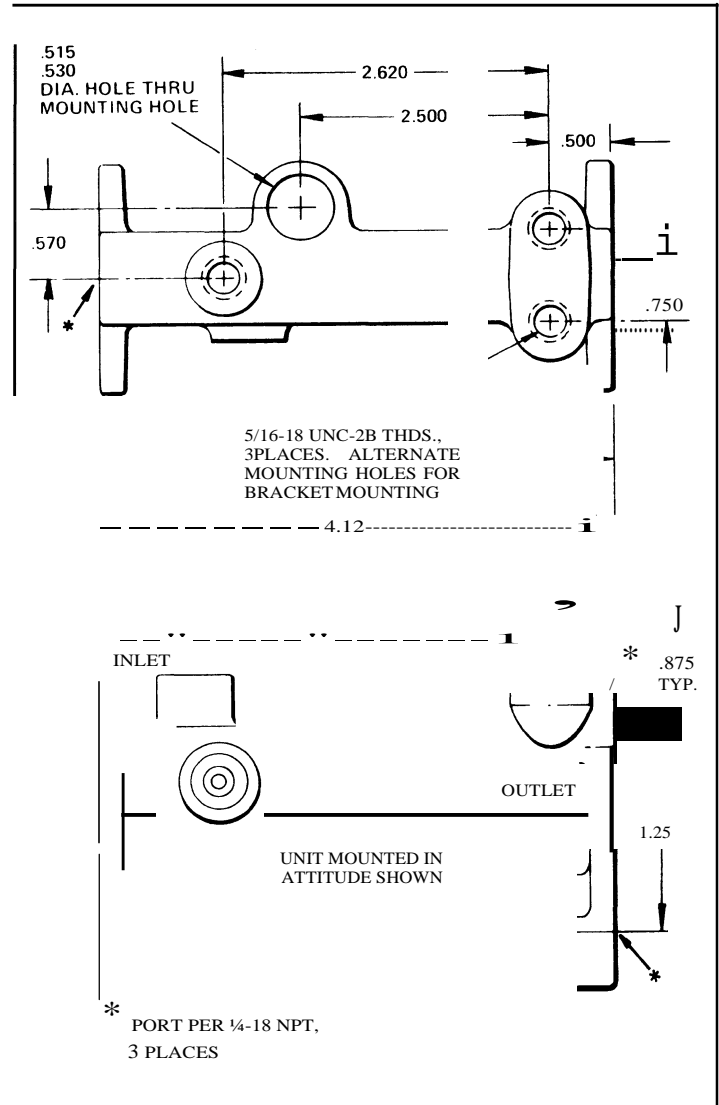

## COLLECTOR CAN DRAIN TUBE INSTALLATION

F613CD (& D) JET LEVEL SENSOR

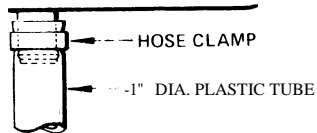

## Meggitt Control Systems

Our product competencies & services:

Aerospace valves | Thermal management solutions | Environmental control systems | Electro-mechanical products

Ground fuelling products | Energy products | Aftermarket services

**Fuelling products**

**F613A (&B) JET LEVEL SENSOR TYPICAL MOUNTING**

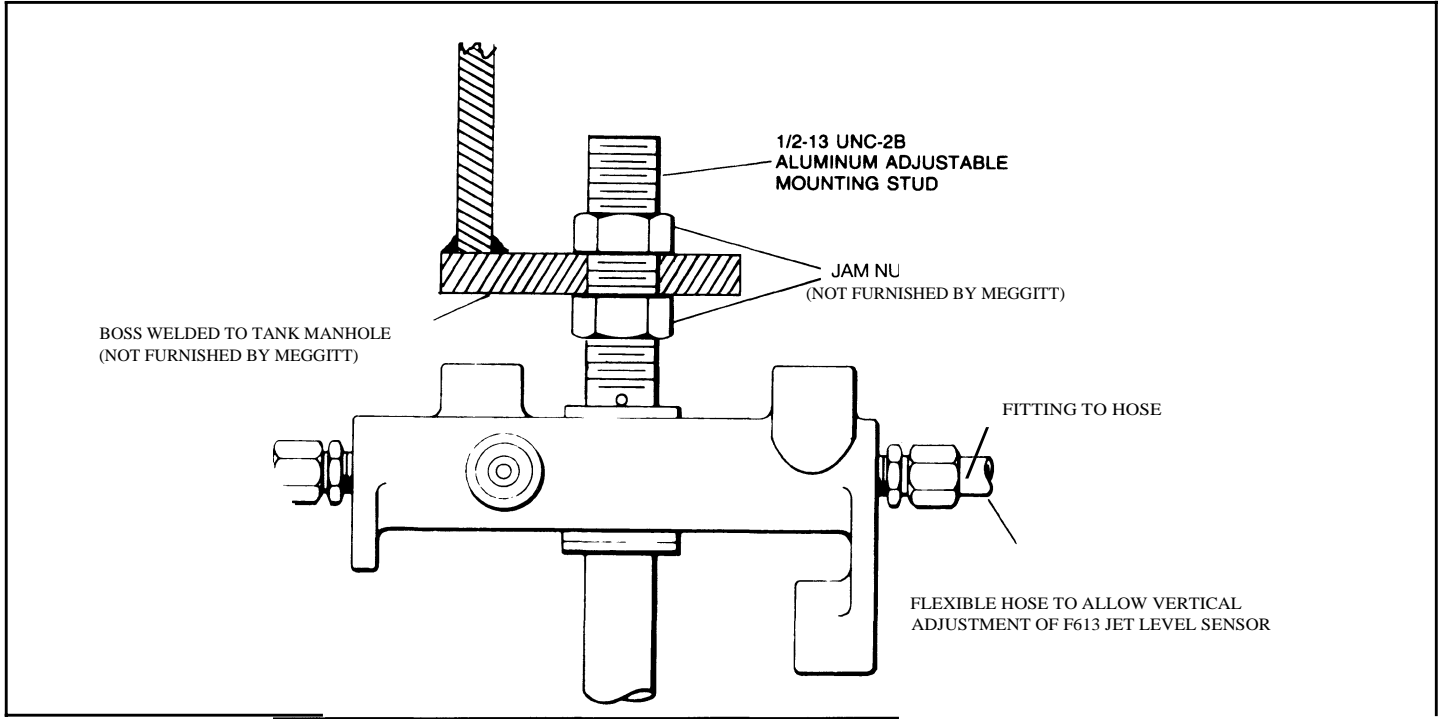

**F613 Modifications**

<b>F613</b>	<b>Jet Level Sensor</b>
A	Adds Adj. Mounting Stud to F613
B	Dual Unit with Adj. Mounting Stud
C	Adds Pre-Check Can to F613, A, D
D	Adds Collector Can to F613, A, C
E	Adds Pre-Check to F613B, F
F	Adds Collector Can to F613B, E

**Meggitt Control Systems**

Our product competencies & services:  
 Aerospace valves | Thermal management solutions | Environmental control systems | Electro-mechanical products  
 Ground fuelling products | Energy products | Aftermarket services



## Fuelling products

## Meggitt Control Systems

Our product competencies & services:

Aerospace valves | Thermal management solutions | Environmental control systems | Electro-mechanical products

Ground fuelling products | Energy products | Aftermarket services