

PRODUCTS - Couplings

Three-inch SELF SEALING INDUSTRIAL COUPLINGS



GENERAL INFORMATION

Avery-Hardoll self sealing couplings are designed for use wherever it is necessary to connect and disconnect hoses and pipelines under pressure, quickly and without spillage. They are designed primarily for use in the petroleum and chemical industries where reliability and safety are of prime concern.

OPERATION

Operation is single action, using a straightforward turning motion to connect the couplings and open a flow path.

An initial push and turn action on the hose unit causes engagement with the tank unit, thus locking and sealing the two units together. Further rotation causes the internal valves to open, thereby allowing flow with minimum pressure drop.

The connection and valve mechanism is interlocked such that the valve can only be opened by fully engaging and sealing the hose unit on its matching tank unit.

On disconnection, the valves fully close before the couplings separate and spillage is therefore negligible.

- LOW COST
- FAIL SAFE TANK UNITS
- UNRIVALLED QUALITY FOR TROUBLE FREE OPERATION AND LONG LIFE
- NEGLIGIBLE SPILLAGE
- ENVIRONMENTALLY FRIENDLY
- HOSE UNIT FITTED WITH SWIVEL AS STANDARD
- EASY SINGLE ACTION COUPLING AND VALVE OPENING
- MATERIAL: GUNMETAL
- NITRILE OR FLUOROCARBON SEALS
- 21 SELECTIVITY OPTIONS

1 - HOSE UNIT

CCMY 6353N*

Materials Gunmetal, St/Steel
 Weight 6.5 kg (14.5 lb)
 Max. working pressure 175 psi (12bar)
 Max. coupling pressure 60 psi (4 bar)
 Test pressure 265 psi (18 bar)

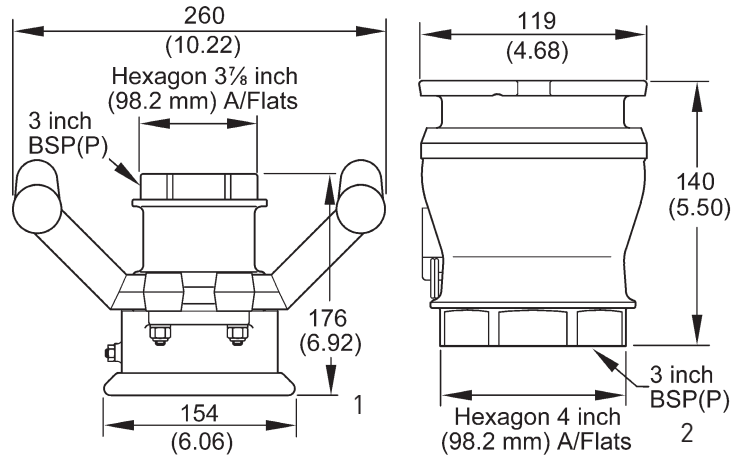

**2 - TANK UNIT
 THREADED VERSION**

CCMY 6351N*

Materials Gunmetal, St/Steel, structural plastic
 Weight 3.15 kg (6.9 lb)
 Max. working pressure 175 psi (12 bar)
 Test pressure 265 psi (18 bar)

**3 - TANK UNIT
 FLANGED VERSION**

CCMY 6350N*

Materials Gunmetal, St/Steel, structural plastic
 Weight 6.5 kg (14.5 lb)
 Max. working pressure 175 psi (12 bar)
 Test pressure 265 psi (18 bar)

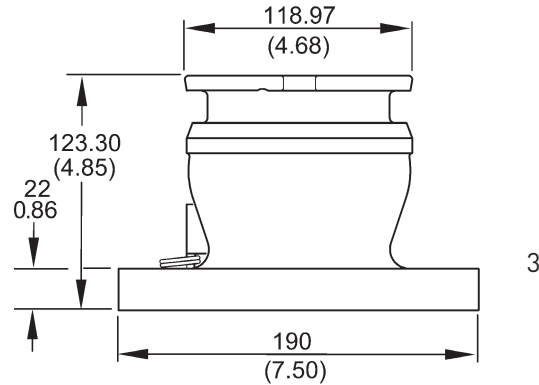

Flanged tank units are normally supplied undrilled, but can be drilled to customer requirements on request

**4 - DUST CAP FOR
 HOSE UNIT**

CCMY 4006*

Material Aluminium alloy
 Weight 0.25 kg (0.56 lb)



**5 - LOCKING CAP FOR
 TANK UNIT**

CCMY 4050

Material Polypropylene
 Weight 0.17 kg (0.37 lb)

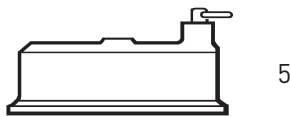

* Seals
 Nitrile as standard
 for fluorocarbon change suffix to V

SELECTIVITY

To avoid product contamination caused by connecting a hose unit to the wrong tank unit, selective versions of the hose and tank units are available.

Selective Position Letter	A	B	C	D	E	F	G
Pin & Slot Position	1&2	1&3	1&4	1&5	1&6	1&7	2&3
Selective Position Letter	H	J	K	L	M	N	P
Pin & Slot Position	2&4	2&5	2&6	2&7	3&4	3&5	3&6
Selective Position Letter	Q	R	S	T	U	V	W
Pin & Slot Position	3&7	4&5	4&6	4&7	5&6	5&7	6&7

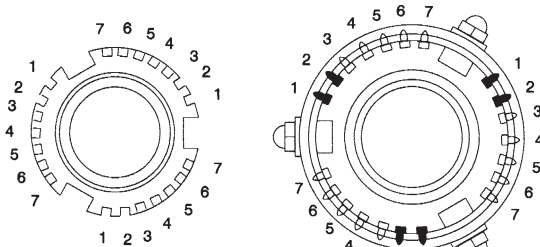

Dimensions in millimeters (inches)

Avery-Hardoll

Holland Way
 Blandford Forum
 Dorset DT11 7BJ
 UK

Whittaker Controls

12838 Saticoy St
 North Hollywood
 California 91605-3505
 USA

Tel: +44 (0) 1258 486600
 Fax: +44 (0) 1258 486601

Tel: +1 818 765 8160
 Fax: +1 818 759 2194